

# Five Zone RF Wireless LED Dimmer

Model:SR-2801 with SR-2501N series



## Feature

- Reliable stable switch and dimming control function, control range  $\geq 20M$ .
- Battery in the remote is with long life span. It normally can use for 2 years.
- Switch on/off of lightings slowly, without any flash, meet the comfort of human eyes.
- Dimming range 0.1-100%.
- Use with power repeater to expand the output power unlimitedly.
- Enable to control 5 zones separately, each zone can be set endless receivers, each receiver maximally be controlled by 8 different remotes.
- Enable be dimmed and ON/OFF by push button after connecting receivers.
- Receivers can work with RF-WIFI converter after installing software on IOS and Android system.
- Push dim function

## Product introduction

The SR-2801 and its receiver is a 5 Zone RF Wireless LED Dimmer. It lets you individually control up to five different zones independently or in a group.

## Parameter

Remote

Part No.	Operation Voltage	Operation Frequency	DIMENSIONS ø/h (mm)
SR-2801	3VDC	434MHz/868MHz	39x136.5x10.7

Receiver

Part No.	Input Voltage	Current	Output	Remarks
SR-2501N	12-36VDC	4x5A	4x(60-180)W	Constant voltage
SR-2501NEA	12-36VDC	4x8A	4x(96-288)W	Constant voltage
SR-2502N	12-36VDC	4x350mA	4x(4.2-12.6)W	Constant current
SR-2503N	12-36VDC	4x700mA	4x(8.4-25.2)W	Constant current

## Product Size

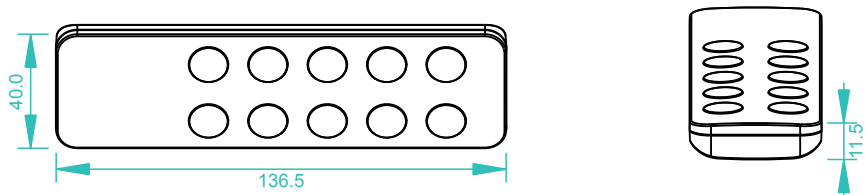

## Wiring diagram

### 1)Receiver Connection Diagram for Single Unit

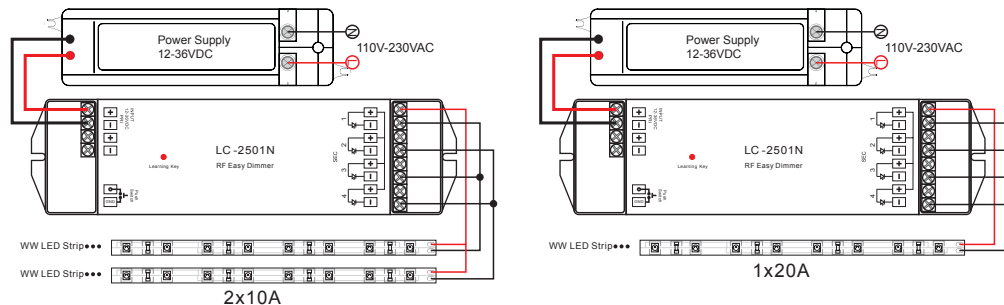
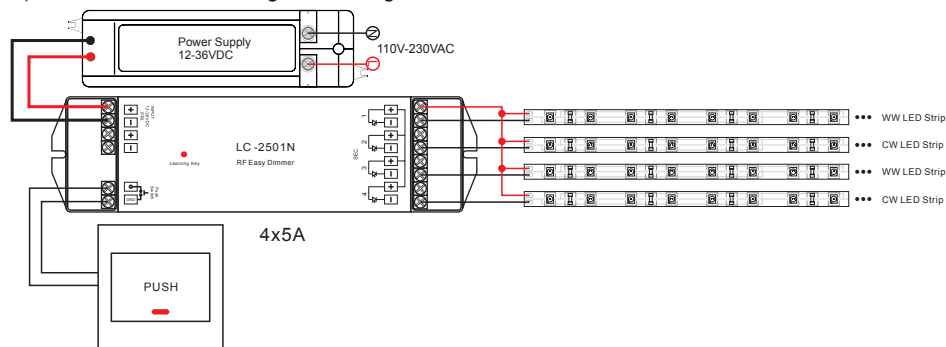

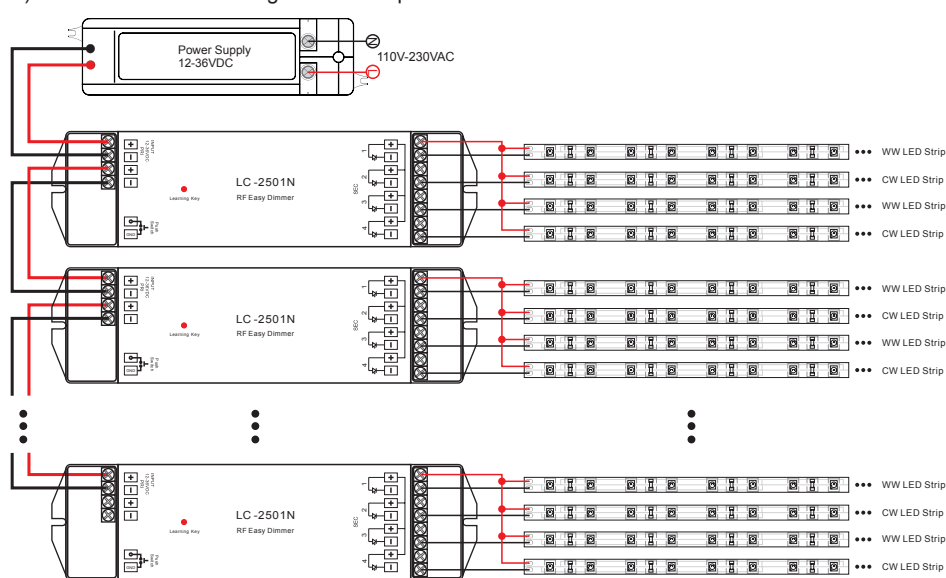

### 2)Receiver Connection Diagram for Multiple Units



## Operation

After you have wired all the receivers according to Figure illustration you need to do the following:

1. Pull off the plastic film cover of the battery at the back of remote.
2. If you use multiple receivers, you have 2 choices:  
Have all receivers in the same zone like Zone 1 for example or  
Have each receiver in a different zone, like Zone 1, 2, 3 and so on
3. In order for each receiver to know what Zone it belongs to, you will need to "pair" it to the zone you wish to use: short press the Learning Key on the receiver, then immediately short press the  or  from the zone you wish to use (for example ON/Off from zone 1). Once you do that, the LED lights will blink once. Now your remote and receiver are paired!
4. Do the same for the other receivers if you use them.

This wireless receiver can work in any of the 5 zones. It has a special "Learning Key" that is in the unit that will enable you to pair it to any of the 5 zones in the wireless remote control. You can add as many optional receivers as you wish, to create up to 5 different control zones. Each zone can have an endless number of receivers, which will let you escalate any installation from small to super-size.

### Memory Reset:

In case you want to reset the memory of the receiver, press the learning function button for 10 seconds while the unit is being powered. The unit will then reset to factory defaults.

### Re-Assign Zone:

Re assigning the receiver to a different zone is easy, just repeat Step 3 as above.

### 5 ZONE REMOTE



A. short press ON button to turn on, long press to dim up

B. short press OFF button to turn off, long press to dim down

C. 5 zone independently control

## Safety & Warnings

- 1) The product shall be installed and serviced by a qualified person.
- 2) IP20. Please avoid the sun and rain. When installed outdoors, please ensure it is mounted in a water proof enclosure.
- 3) Always be sure to mount this unit in an area with proper ventilation to avoid overheating.
- 4) Please check if the output voltage of any LED power supplies used comply with the working voltage of the product.
- 5) Never connect any cables while power is on and always assure correct connections to avoid short circuits before switching on.
- 6) Please ensure that the cable is secured tightly in the connector
- 7) For update information please consult your supplier.

## Warranty Agreement

- 1) We provide lifelong technical assistance with this product:
  - 3-year warranty. We print date on every products, for example :1125 means year 2011, week 25. The warranty is for free repair or replacement and covers manufacturing faults only.
  - For faults beyond the 3-year warranty we reserve the right to charge for time and parts.
- 2) Limited Warranty
  - Any defects caused by wrong operation.
  - Any damages caused by unauthorized removal, maintenance, modifying, incorrect connection and replacement of chips.
  - Any damages due to transportation, vibration etc. after purchase.
  - Any damages caused by earthquake, fire, lightning, pollution and abnormal voltage.
  - Any damages caused by negligence, inappropriate storing at high temperatures and humidity or near harmful chemicals.
  - Product has been updated
- 3) Repair or replacement as provided under this warranty is the exclusive remedy to the customer.